



# AN1348 APPLICATION NOTE

## ST485: AN RS-485 BASED INTERFACE WITH LOWER DATA BIT ERRORS

A. Randazzo

### 1. INTRODUCTION

ST485 is a RS-485 based interface designed for multipoint differential transmission on a single twisted pair cable. It allows half duplex bi-directional transmission, long cable length and high data rate. Typical applications include LANs, industrial (PLC devices), automotive and computer interfaces. The system evolution in the data communication field leads to the development of faster devices with lower data bit errors and ST485 meets all these requirements.

### 2. FUNCTIONAL DESCRIPTION

Figure 1 shows the internal structure of the ST485. The driver and receiver line pins are connected together; in fact the bi-directional communication can only be half-duplex. The control pins  $\overline{RE}$  and DE are used to enable respectively the receiver and driver and, in many applications, are connected together. The driver has a TTL input while the output is differential. The receiver differential input is internally connected to the driver output.

Figure 1: ST485 Internal Structure

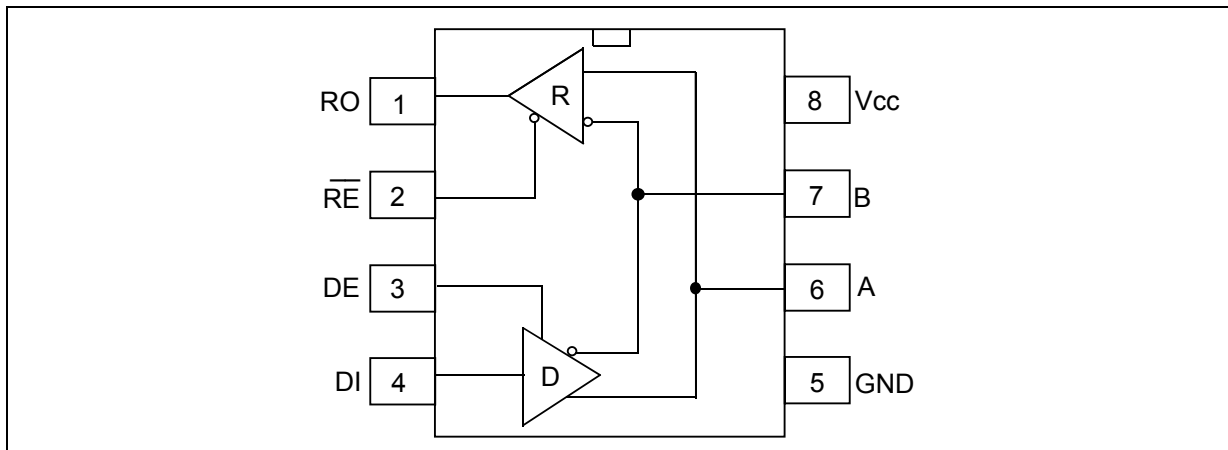

The Vcc supply voltage is 5V, typical DC consumption is less than 0.5mA without load and Data rate is greater than 10Mbps.

### 3. FEATURES

The most important parameters in a RS-485 device are:

- The receiver input threshold. It is  $\pm 200\text{mV}$ . This feature ensures an improvement of the noise immunity;
- The receiver input resistance. It should be high enough to allow the connection of many transceivers

- together. ST485 has a  $R_{in}$  greater than 40kOhm allowing the connection of more than 32 units as well;
- The common mode voltage  $V_{CM}$  for the receiver, defined as the algebraic mean of the two local-ground-referenced voltage:  $V_{CM}=(V_A+V_B)/2$ . This parameter is from -7V to +12V for RS-485 standard.  $V_{CM}$  enables different ground-referenced devices to work correctly and allowing ground difference up to  $\pm 7V$ . For an example see figure 2;
  - The differential driver output voltage. It depends on the driver output current and, obviously, on the used  $R_{LOAD}$ . It must be greater than 1.5V with 270Ohm  $R_{LOAD}$ ;
  - The driver short-circuit protection; it should happen that more drivers transmit at the same time giving a conflict. ST485 limits the short circuit current up to 70mA providing a protection for the whole line.

Figure 2: Common Mode Voltage Capability

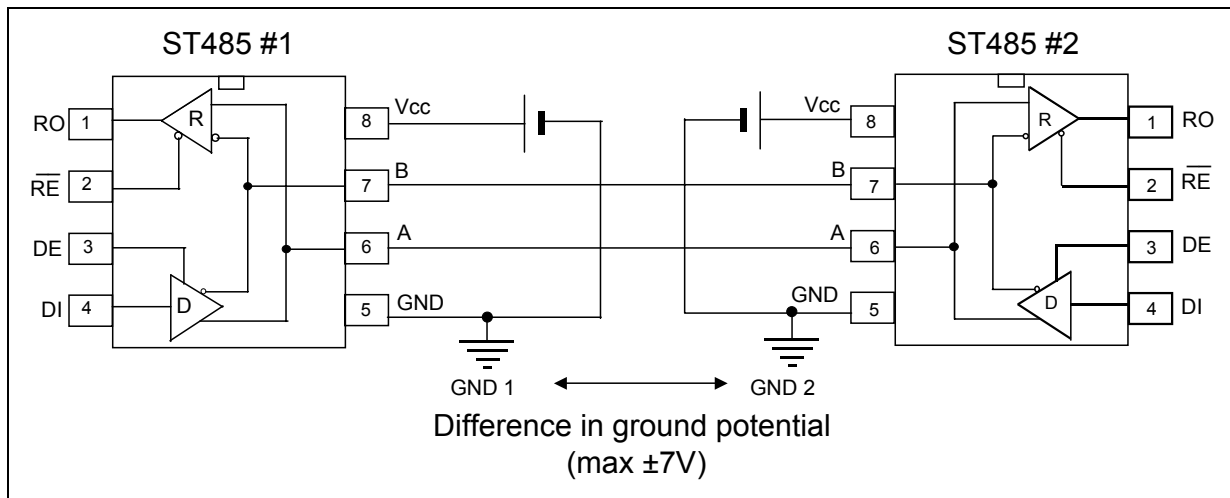

#### 4. DIFFERENTIAL LINE ADVANTAGES

Why differential line transmission?

- When a signal is transmitted on a single twisted cable, many factors contribute to increase disturbs on the line, like spike and induced currents. With a differential transmission the same induced disturb is present on both input A and B, so the difference is null. Figure 3 shows the signal ground-referenced of the ST485 inputs A and B with a noise signal induced; CH1= receiver input A, CH2= receiver input B, CH4= receiver output. The common mode disturb is not present on the receiver output.

Figure 3: Common mode Noise Signal Induced on a ST485 Differential Line

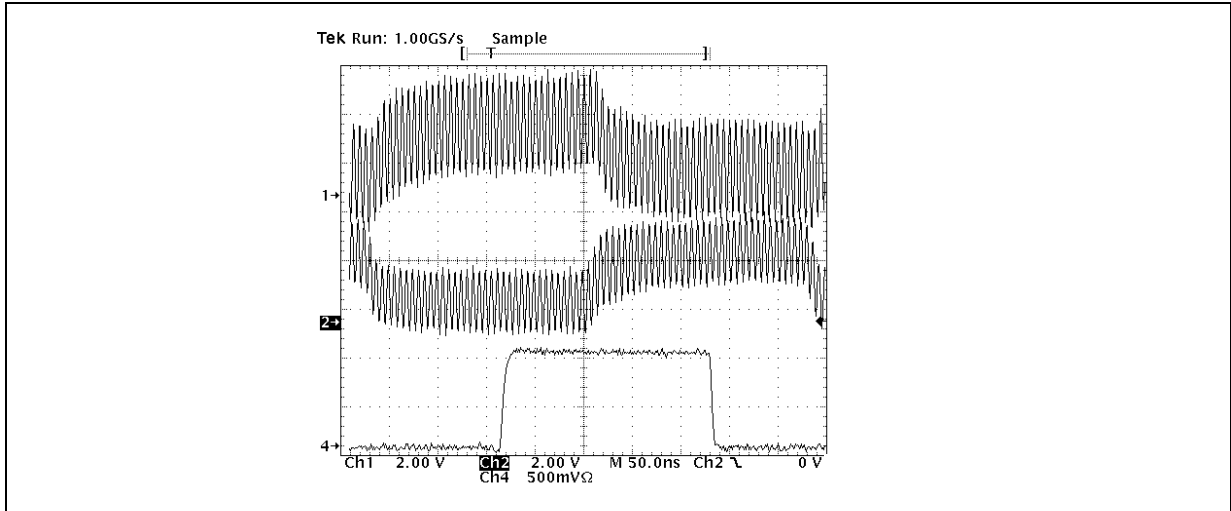

- In a single ended transmission the distance between logic symbol '1' and '0' is lower respect to the differential one. Table 1 and figure 4 show that, with  $V_{cc}=5V$ , the voltage distance between '1' and '0' logic symbols is 10V without load. Obviously the termination (120Ohm for a twisted cable or 54Ohm for a shield cable) reduces this voltage distance.

Figure 4: Single Ended and Differential Signals

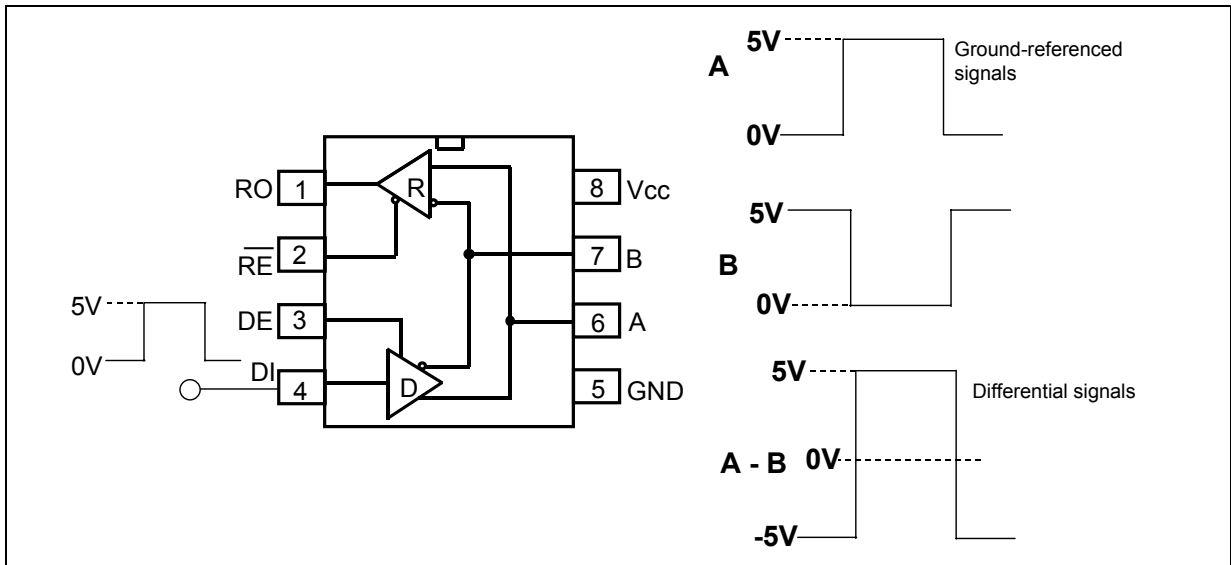

Table 1: Single Ended and Differential Signals

Logic Level	Single Ended	Differential Referenced to ground	Differential ( $V_A - V_B$ )
0	$V_{out}=0V$	$V_{out}: A=0V; B=5V$	$V_{diff} = 0V - 5V = -5V$
1	$V_{out}=5V$	$V_{out}: A=5V; B=0V$	$V_{diff} = 5V - 0V = +5V$

5. APPLICATIONS

A typical ST485 application is the network allowing the connection of up to 32 devices; termination resistances are tied only on the first and last unit and the value depend on the line impedance (54Ohm or 120Ohm), see figure 5. By connecting a node to the line, a stub is created and its length should be lower than 15cm (6inches) to avoid transmission problems.

Figure 5: Typical RS-485 Line

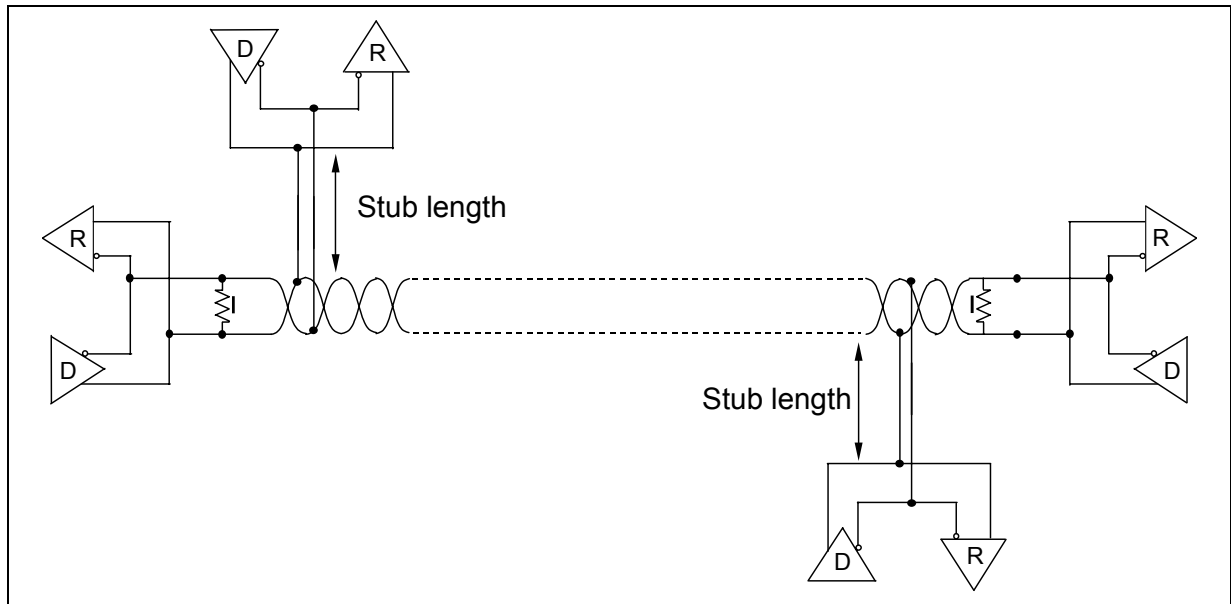

In order to avoid wrong data transmission and signal reflections all the transceiver should be connected sequentially among them, like figures 6b and 6d (6a and 6c are bad configurations).

Figure 6: Typical Network Connections

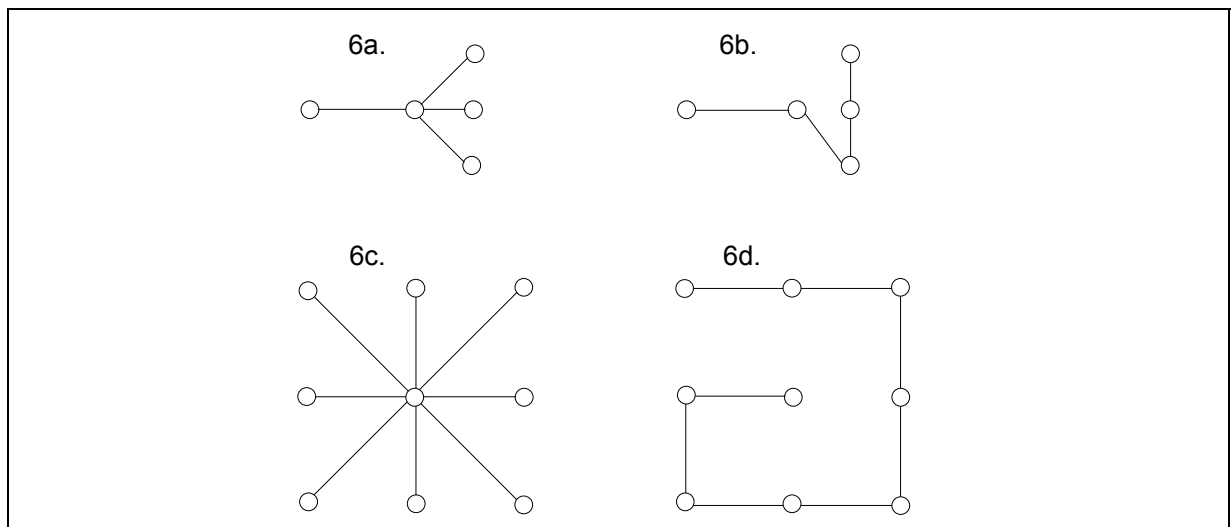

## 6. ADVICE

### 6.1 Stabilization of Output $V_{CM}$

In order to get greater cable length and higher data rate, with a better signal quality, the following load connection is useful. This configuration, shown in figure 7, allows output  $V_{CM}$  voltage filtering and to reduce the common mode disturbs.

**Figure 7: Configuration to Improve Transmission Performance**

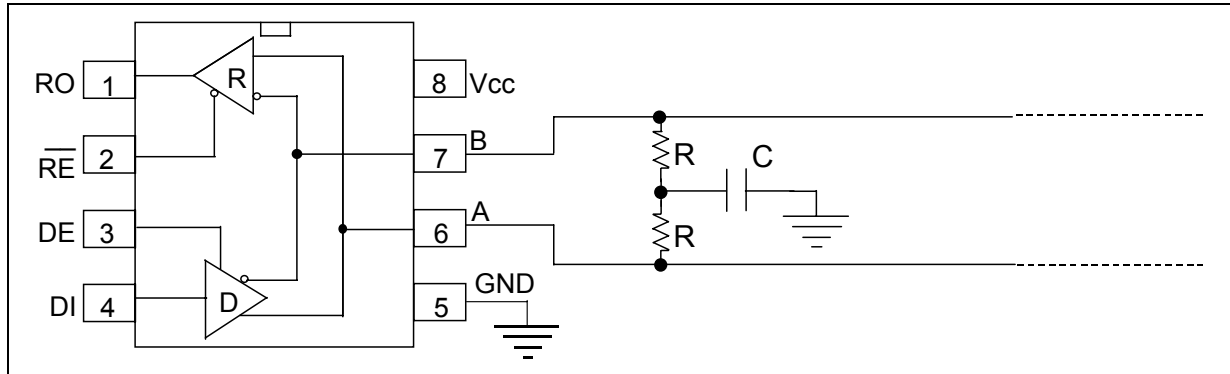

Note:  $R=R_{LOAD}/2$ ,  $C=1/10nF$  ceramic or polyester capacitor.

### 6.2 AC Termination

The standard  $R_{LOAD}$  termination often causes an increase of power consumption, so to minimize the DC loop current flowing on the load, in static conditions, the configuration shown in figure 8 is useful. The  $R$  value depends on the line impedance, typically it is 120Ohm for twisted pair cables;  $C$  depends either on the cable length or on the line impedance  $Z_0$  and must be calculated to result a short-circuit for data transmission. However, this configuration limits the data rate because of the low pass filter make with  $R$  and  $C$ , then it is useful for medium data rate.

**Figure 8: Configuration to Reduce the DC Loop Current**

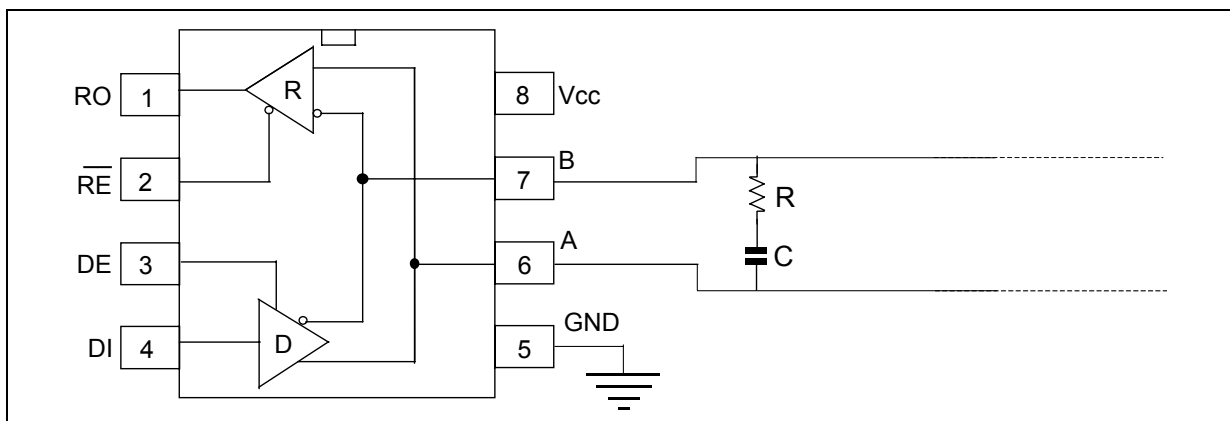

Note: The  $C$  capacitor breaks the DC loop current when data transmission is off and reduces the power consumption but limits the data rate.

### 6.3 Fail Safe Termination

ST485 has an internal failsafe circuit useful when the differential input is floating, for instance, if all the drivers on the line are in Hi-impedance state. Failsafe circuit avoids undefined state of the receiver that stays in a stable logic level, until the input differential voltage exceeds the  $\pm 200\text{mV}$ . However the internal failsafe resistors are influenced from the external termination loader ( $54 \div 120\Omega$ ) so that an external failsafe circuit is required if the termination resistor is present. A typical failsafe configuration is shown in figure 9. The two resistors  $R_a$  (pull-up) and  $R_c$  (pull-down) should be  $500\Omega$  while  $R_b$  (load) is  $130\Omega$ .

Figure 9: Failsafe Configuration

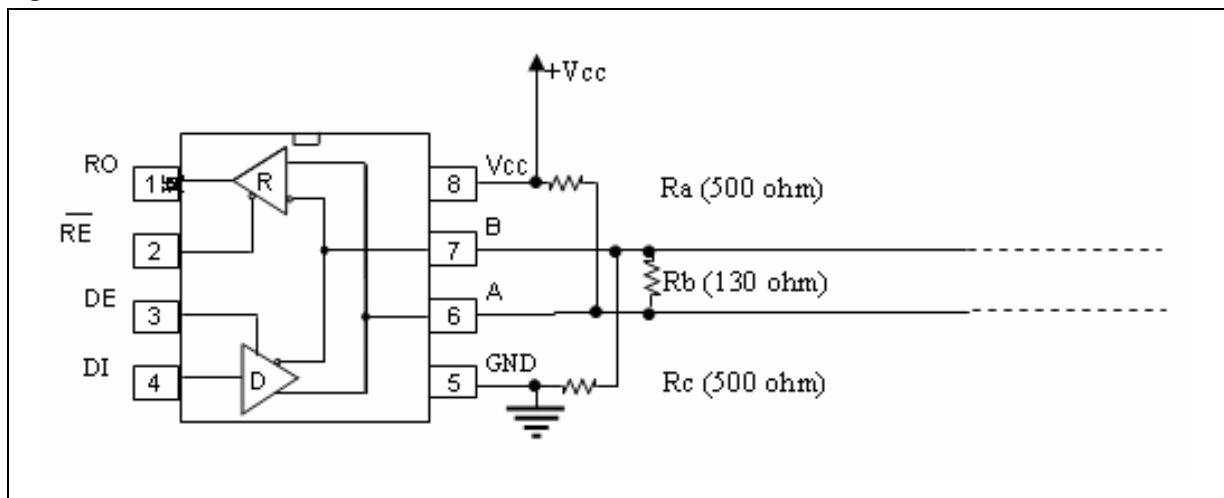

This load reduces the maximum numbers of transceiver connected to the network and causes a DC current consumption. Figure 10 shows a solution of how to reduce the DC current.

Figure 10: Failsafe Configuration with Low DC Current

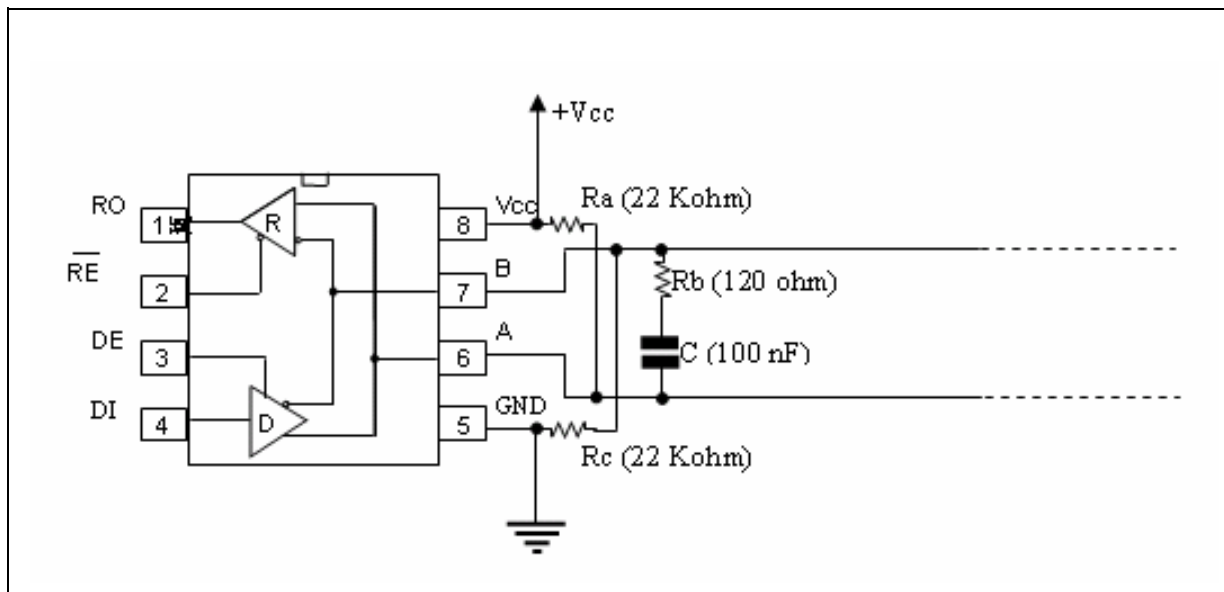

Information furnished is believed to be accurate and reliable. However, STMicroelectronics assumes no responsibility for the consequences of use of such information nor for any infringement of patents or other rights of third parties which may result from its use. No license is granted by implication or otherwise under any patent or patent rights of STMicroelectronics. Specifications mentioned in this publication are subject to change without notice. This publication supersedes and replaces all information previously supplied. STMicroelectronics products are not authorized for use as critical components in life support devices or systems without express written approval of STMicroelectronics.

The ST logo is a registered trademark of STMicroelectronics.  
All other names are the property of their respective owners

© 2004 STMicroelectronics - All rights reserved

**STMicroelectronics GROUP OF COMPANIES**

Australia - Belgium - Brazil - Canada - China - Czech Republic - Finland - France - Germany - Hong Kong - India - Israel - Italy - Japan -  
Malaysia - Malta - Morocco - Singapore - Spain - Sweden - Switzerland - United Kingdom - United States  
[www.st.com](http://www.st.com)