

4 3 2 1

DRAWING MADE IN THIRD ANGLE PROJECTION

THIS DRAWING IS UNPUBLISHED.

RELEASED FOR PUBLICATION

,19

© COPYRIGHT 19

BY AMP INCORPORATED. ALL INTERNATIONAL RIGHTS RESERVED.

LOC	DIST	P	F	ZONE	LTR	REVISIONS	DESCRIPTION	DATE	APPD
G	14					0	RELEASED PER 0720-0008-93	3-1-93	1 st DAP

METRIC

DIMENSIONS LISTED IN mm [INCHES]

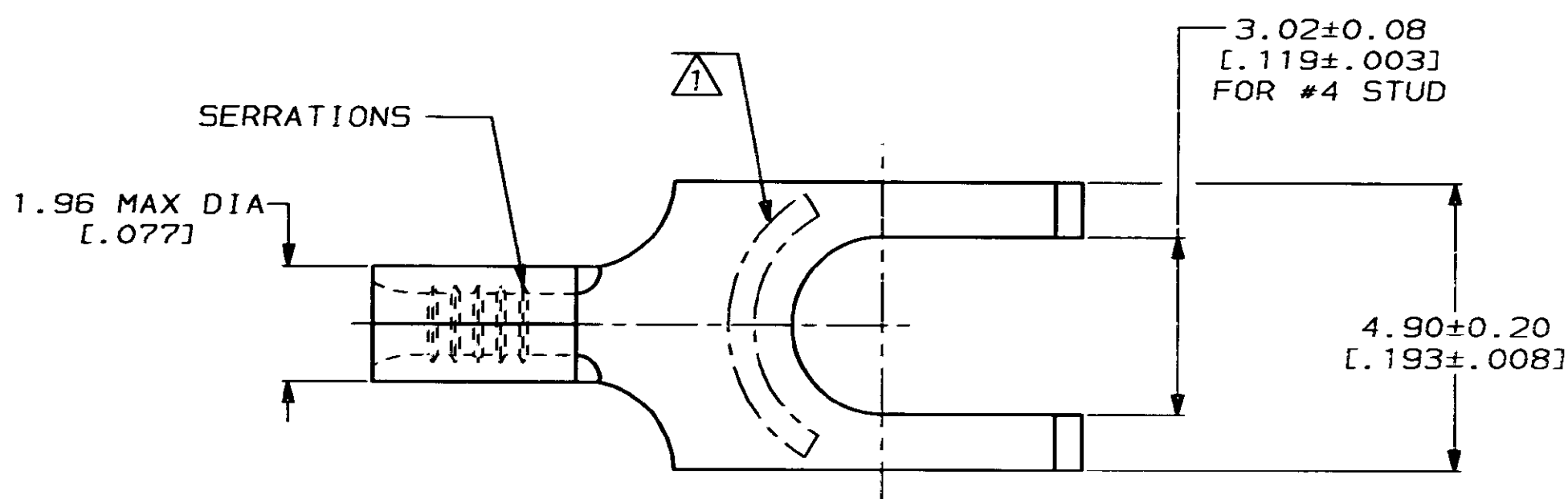

AMP WIRE RANGE	E13288 Listed
26-22 AWG STRANDED	NOT LISTED
LR7189 Certified	MILITARY P/N AND CLASS
NOT CERTIFIED	NOT APPLICABLE

△ STAMP AMP APPROX AS SHOWN

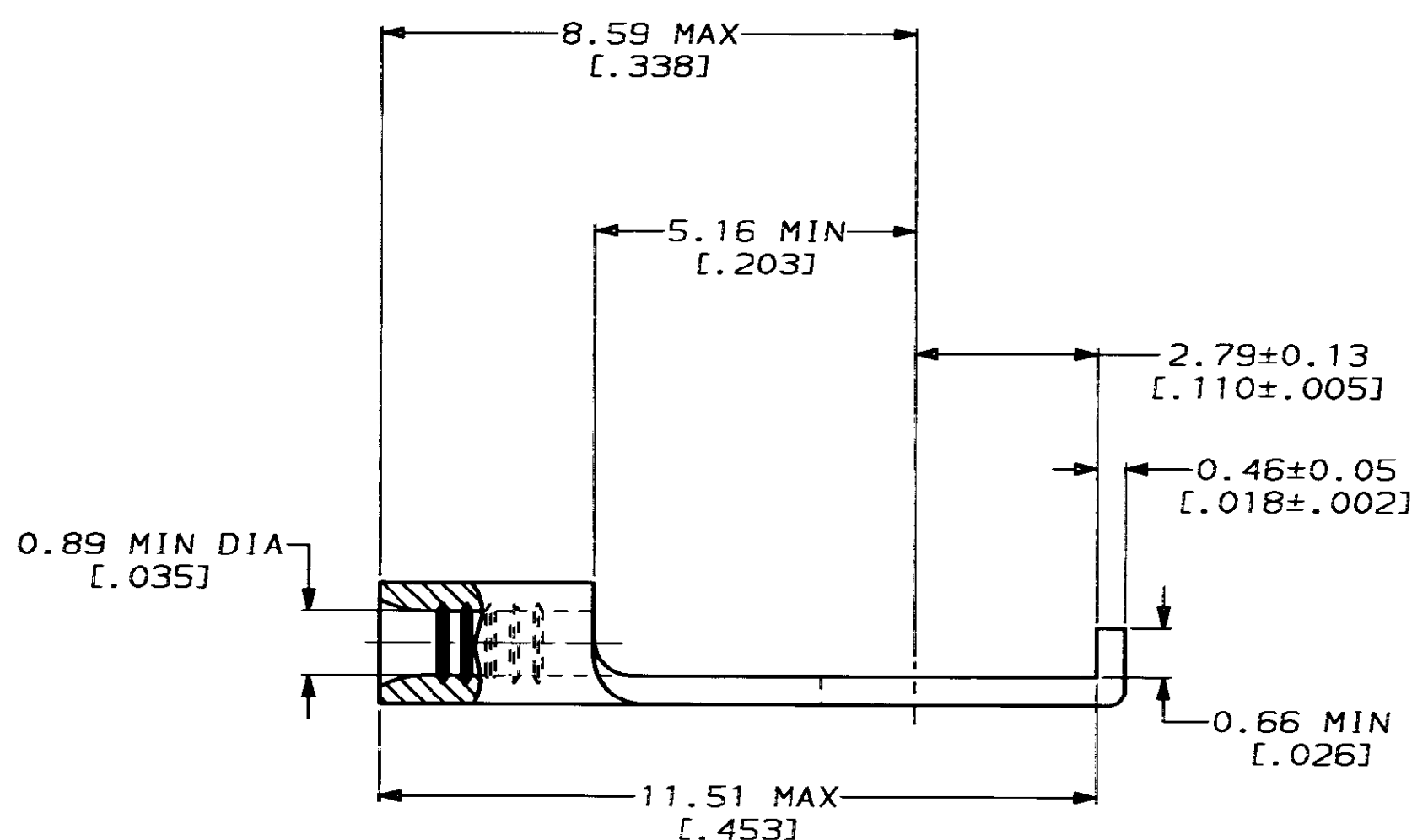

52512-1

PART NO

AMP INCORPORATED
CUSTOMER SERVICE SYSTEMS

MAX RECOMMENDED OPERATING
TEMPERATURE:

170°C MAX

VOLTAGE RATING:

NOT APPLICABLE

WIRE CROSS SECTIONAL AREA RANGE:
0.1-0.41mm² [202-810] CIR MILS
STRANDED

THIS DRAWING IS A CONTROLLED DOCUMENT FOR
AMP INCORPORATED. IT IS SUBJECT TO CHANGE
AND THE CONTROLLING ENGINEERING ORGANIZATION
SHOULD BE CONTACTED FOR THE LATEST REVISION.

DO NOT SCALE PRINT.
UNLESS SPECIFIED
DIMENSIONS IN mm [INCHES]
TOLERANCES ON:
2 PLC DEC ± -
3 PLC DEC ± -
ANGLES ± -

MATERIAL
COPPER PER
ASTM B-152
ANNEALED

FINISH
TIN PLATE
0.00254 [0.00100] MIN
THK PER MIL-T-10727

DR 3-1-93
TA BRINKMAN

CHK 3-1-93
DA PATTERSON

APPD 3-1-93
DE MILLER

APPD 3-1-93
JL MECKLEY

PRODUCT SPEC

APPLICATION SPEC

WEIGHT -

AMP AMP Incorporated
Harrisburg, PA 17105-3608

NAME

TERMINAL, FLANGED
SPADE, BUDGET

SIZE
C 00779

SCALE 10:1

CAGE CODE
00779

DRAWING NO
C-52512

SHEET 1 OF 1