

Overview

FMD Series Supercapacitors, also known as Electric Double-Layer Capacitors (EDLCs), are intended for power back up in the automotive applications.

Enhancements to the design and selected material upgrades were introduced to deliver 1,000 hours at 85°C/85% RH rated voltage and Automotive Testing Protocol with extended maximum operational temperature life up to 85°C. These capacitors are manufactured in an ISO TS 16949 certified plant and are subjected to PPAP/PSW, as well as change control.

Applications

Supercapacitors have characteristics ranging from traditional capacitors and batteries. As a result, supercapacitors can be used like a secondary battery when applied in a DC circuit. These devices are best suited for use in low voltage DC hold-up applications such as embedded microprocessor systems with flash memory.

FMD type Automotive grade Supercapacitor can be stable under harsh environmental conditions such as high humidity and high temperature.

Benefits

- Automotive Testing Protocol
- TS 16949 certified plant
- Subject to PPAP/PSW and change control
- Wide range of temperature from -40°C to +85°C
- Maintenance free
- Maximum operating voltage of 5.5 VDC
- Highly reliable against liquid leakage
- Lead-free and RoHS compliant

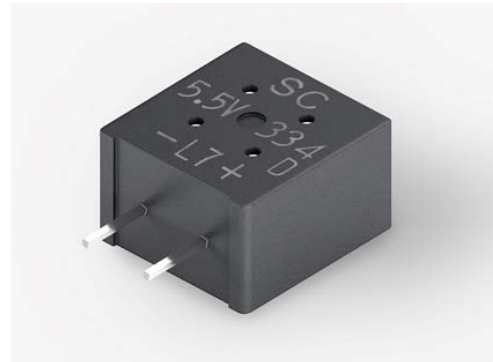

Part Number System

FMD	0H	334	Z	F	TP	18
Series	Maximum Operating Voltage	Capacitance Code	Capacitance Tolerance	Environmental	Tape Type	Height (excluding lead)
FMD	0H = 5.5 VDC	First two digits represent significant figures. Third digit specifies number of zeros to follow μF code.	Z = -20/+80%	F = Lead-free	TP = Ammo Blank = Bulk	18 = 18 mm Blank = Bulk

Dimensions – Millimeters

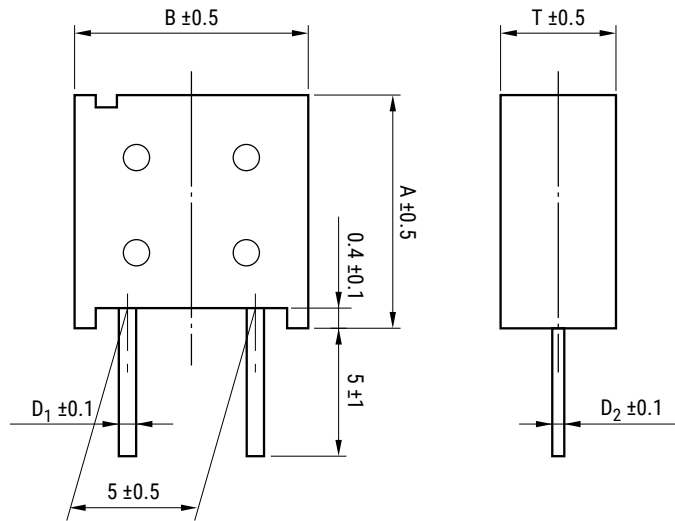

Part Number	A	B	T	D ₁	D ₂
FMD0H334ZF	15	14	9	0.6	0.6

Environmental Compliance

All KEMET supercapacitors are RoHS compliant.



Table 1 – Ratings & Part Number Reference

Part Number	Maximum Operating Voltage (VDC)	Nominal Capacitance		Maximum ESR at 1 kHz (Ω)	Maximum Current at 30 Minutes (mA)	Voltage Holding Characteristic Minimum (V)	Reference Weight (g)
		Charge System (F)	Discharge System (F)				
FMD0H334ZF	5.5	-	0.33	25	0.50	4.2	3.8

Specifications

Item		Specifications	Test Conditions	
Category temperature range		-40°C to +85°C		
MAX operating voltage		Refer to standard ratings		
Capacitance		Refer to standard ratings	Refer to "Measurement Conditions"	
Capacitance allowance		+80%, -20%	Refer to "Measurement Conditions"	
ESR		Refer to standard ratings	Measured at 1 kHz, 10 mA, See also "Measurement Conditions"	
Current (30 minute value)		Refer to standard ratings	Refer to "Measurement Conditions"	
Self discharge characteristics (voltage holding characteristics)		Voltage between terminal leads higher than 4.2 V	Charging	Voltage applied: 5.0 VDC Series resistance: 0 Ω Let stand for 24 hours
			Storage	Let stand for 24 hours in described below with terminals opened Ambient temperature: Lower than 25°C Relative humidity: Lower than 70°C
High Temperature Exposure (Storage)	MIL-STD-202 Method 108	Capacitance	Within ±30% of initial measured value	Temperature: 85 ±2°C
		ESR	Less than 200% of initial limit	Testing time: 1,000 ⁺⁴⁸ ₋₀ hours
		Current	Less than 200% of initial limit	
Temperature Cycling	JESD22 Method JA-104	Capacitance	Within ±30% of initial measured value	Temperature condition: Lower -40°C » Upper +85°C
		ESR	Less than 200% of initial limit	Dwell Time: 30 minutes
		Current	Less than 200% of initial limit	Transition time: Maximum 1 minute Number of cycles: 1,000 Cycles
Biased humidity	MIL-STD- 202 Method 103	Capacitance	Within ±30% of initial measured value	Temperature: 85±2°C Relative humidity: 80 to 85%RH Voltage applied: MAX operating voltage
		ESR	Less than 200% of initial limit	Series protection resistance: 0 Ω
		Current	Less than 200% of initial limit	Testing time: 1,000 ⁺⁴⁸ ₋₀ hours
Operational life	MIL-STD- 202 Method 108	Capacitance	Within ±30% of initial measured value	Temperature: 85±2°C
		ESR	Less than 200% of initial limit	Voltage applied: MAX operating voltage
		Current	Less than 200% of initial limit	Series protection resistance: 0 Ω Testing time: 1,000 ⁺⁴⁸ ₋₀ hours
Lead strength (Tensile)	MIL-STD-202 Method 211	No terminal damage	Test leaded device lead integrity only. A (454 g), C (227 g)	
Mechanical shock	MIL-STD-202 Method 213	Capacitance	Satisfy initial limit	Figure 1 of Method 213 Condition C
		ESR		
		Current		
Solderability	J-STD-002			Conforms to Method A1 (Through Hole Technology) Solder temp: 245±5°C Dipping time: 5 +0/-0.5 second
		Appearance	Minimum 95% of the terminal should be covered by the new solder	1.6mm from the bottom should be dipped.
Vibration	MIL-STD-202 Method 204	Capacitance	Satisfy initial limit	Frequency: 10 to 2,000 Hz (5 g's)
		ESR		Testing time: 12 hours
		Current		

Specifications cont.

Item		Specifications		Test Conditions	
Resistance to Soldering Heat	MIL-STD- 202 Method 210	Capacitance	Satisfy initial limit	Solder temp: 260±10°C Dipping time: 3 seconds 2.0 mm from the bottom should be dipped. Condition B no pre-heat of samples. Note: Single Wave Solder. Procedure 1 with solder within 1.5 mm of device body for Leaded.	
		ESR			
		Current			
Temperature Stability	IEC-62391-1	Capacitance	Phase2	More than 50% of initial measured	Phase1: +25±2°C Phase2: -25±2°C Phase3: -40±2°C Phase4: +25±2°C Phase5: +85±2°C Phase6: +25±2°C
		ESR		Less than 400% of initial measured	
		Capacitance	Phase3	More than 30% of initial measured	
		ESR		Less than 700% of initial measured	
		Capacitance	Phase5	Less than 200% of initial measured	
		ESR		Satisfy initial specified value	
		Current		1.5 CV (mA) or below	
		Capacitance	Phase6	Within ±20% of initial measured value	
		ESR		Satisfy initial specified value	
Current	Satisfy initial specified value				

Marking

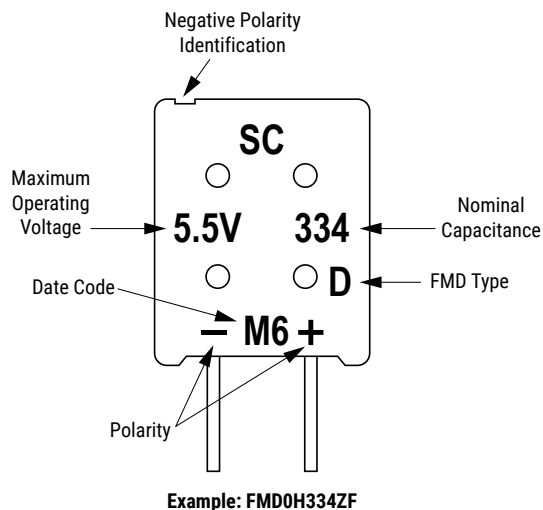

Packaging Quantities

Part Number	Bulk Quantity per Box Straight Lead	Ammo Pack Quantity
FMD0H334ZF	400 pieces	400 pieces

Ammo Pack Taping Format

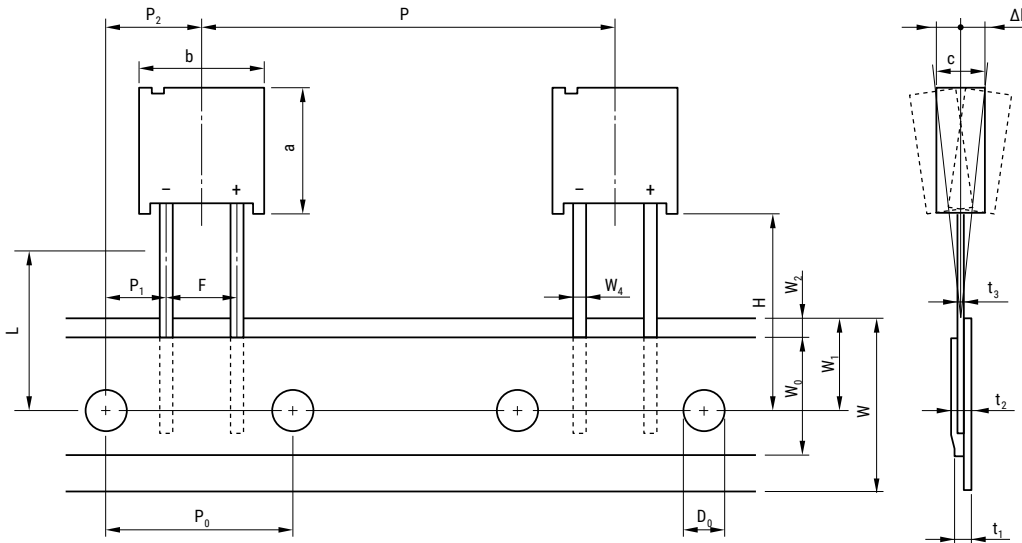

Ammo Pack Taping Specifications

Item	Symbol	Dimensions (mm)
Component Height	a	15.0±0.5
Component Width	b	14.0±0.5
Component Thickness	c	9.0±0.5
Lead-Wire Width	W_4	0.6±0.1
Lead-Wire Thickness	t_3	0.6±0.1
Component Pitch	P	25.4±1.0
Sprocket Hole Pitch	P_0	12.7±0.3
Sprocket Hole Center to Lead Center	P_1	3.85±0.7
Sprocket Hole Center to Component Center	P_2	6.35±0.7
Lead Spacing	F	5.0±0.5
Component Alignment (side/side)	Δh	2.0 Maximum
Carrier Tape Width	W	18.0+1.0/-0.5
Hold-Down Tape Width	W_0	12.5 Minimum
Sprocket Hole Position	W_1	9.0±0.5
Hold-Down Tape Position	W_2	3.0 Maximum
Height to Seating Plane (lead length)	H	16.0±0.5/18.0±0.5
Sprocket Hole Diameter	D_0	∅ 4.0±0.2
Carrier Tape Thickness	t_1	0.67±0.2
Total Thickness (Carrier Tape, Hold-Down Tape and Lead)	t_2	1.7 Maximum
Cut Out Length	L	11.0 Maximum

Measurement Conditions

Capacitance (Discharge System)

As shown in the diagram below, charging is performed for a duration of 30 minutes once the voltage of the capacitor terminal reaches 5.5 V. Then, use a constant current load device and measure the time for the terminal voltage to drop from 3.0 to 2.5 V upon discharge at 0.33 mA per 0.33 F, for example, and calculate the static capacitance according to the equation shown below.

Note: The current value is 1 mA discharged per 1 F.

$$C = \frac{I \times (T_2 - T_1)}{V_1 - V_2} \text{ (F)}$$

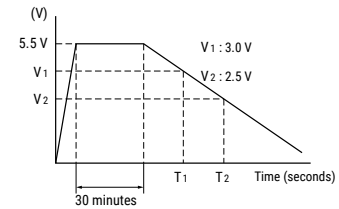
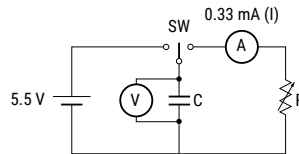

Equivalent Series Resistance (ESR)

ESR shall be calculated from the equation below.

$$ESR = \frac{V_C}{0.01} \text{ (}\Omega\text{)}$$

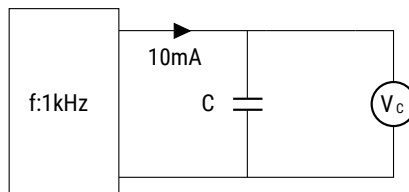

Current (at 30 minutes after charging)

Current shall be calculated from the equation below. Prior to measurement, both lead terminals must be short-circuited for a minimum of 30 minutes. The lead terminal connected to the metal can case is connected to the negative side of the power supply.

E_0 : 5.0 VDC

R_C : 100 Ω

$$\text{Current} = \frac{V_R}{R_C} \text{ (A)}$$

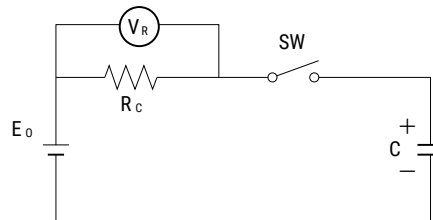

Self-Discharge Characteristic

The self-discharge characteristic is measured by charging a voltage of 5.0 VDC (charge protection resistance: 0 Ω) according to the capacitor polarity for 24 hours, then releasing between the pins for 24 hours and measuring the pin-to-pin voltage. The test should be carried out in an environment with an ambient temperature of 25°C or below and relative humidity of 70% RH or below. The soldering is checked.

Dismantling

There is a small amount of electrolyte stored within the capacitor. Do not attempt to dismantle as direct skin contact with the electrolyte will cause burning. This product should be treated as industrial waste and not be disposed of by fire.

Notes on Using Supercapacitors or Electric Double-Layer Capacitors (EDLCs)

1. Circuitry Design

1.1 Useful life

Supercapacitor (EDLC) uses an electrolyte in a sealed container. Water in the electrolyte can evaporate while in use over long periods of time at high temperatures, thus reducing electrostatic capacity which in turn will create greater internal resistance. The characteristics of the supercapacitor can vary greatly depending on the environment in which it is used. Basic breakdown mode is an open mode due to increased internal resistance.

1.2 Fail rate in the field

Based on field data, the fail rate is calculated at approximately 0.006 Fit. We estimate that unreported failures are ten times this amount. Therefore, we assume that the fail rate is below 0.06 Fit.

1.3 Exceeding maximum usable voltage

Performance may be compromised and in some cases leakage or damage may occur if applied voltage exceeds maximum working voltage.

1.4 Use of capacitor as a smoothing capacitor (ripple absorption)

As supercapacitors contain a high level of internal resistance, they are not recommended for use as smoothing capacitors in electrical circuits. Performance may be compromised and, in some cases, leakage or damage may occur if a supercapacitor is used in ripple absorption.

1.5 Series connections

As applied voltage balance to each supercapacitor is lost when used in series connection, excess voltage may be applied to some supercapacitors, which will not only negatively affect its performance but may also cause leakage and/or damage. Allow ample margin for maximum voltage or attach a circuit for applying equal voltage to each supercapacitor (partial pressure resistor/voltage divider) when using supercapacitors in series connection. Also, arrange supercapacitors so that the temperature between each capacitor will not vary.

1.6 Case Polarity

The supercapacitor is manufactured so that the terminal on the outer case is negative (-). Align the (-) symbol during use. Even though discharging has been carried out prior to shipping, any residual electrical charge may negatively affect other parts.

1.7 Use next to heat emitters

Useful life of the supercapacitor will be significantly affected if used near heat emitting items (coils, power transistors and posistors, etc.) where the supercapacitor itself may become heated.

1.8 Usage environment

This device cannot be used in any acidic, alkaline or similar type of environment.

Notes on Using Supercapacitors or Electric Double-Layer Capacitors (EDLCs) cont.

2. Mounting

2.1 Mounting onto a reflow furnace

Except for the FC series, it is not possible to mount this capacitor onto an IR / VPS reflow furnace. Do not immerse the capacitor into a soldering dip tank.

2.2 Flow soldering conditions

Keep solder under 260°C and soldering time to within 10 seconds when using the flow automatic soldering method. (Except for the FC and HV series)

2.3 Installation using a soldering iron

Care must be taken to prevent the soldering iron from touching other parts when soldering. Keep the tip of the soldering iron under 400°C and soldering time to within 3 seconds. Always make sure that the temperature of the tip is controlled. Internal capacitor resistance is likely to increase if the terminals are overheated.

2.4 Lead terminal processing

Do not attempt to bend or polish the capacitor terminals with sand paper, etc. Soldering may not be possible if the metallic plating is removed from the top of the terminals.

2.5 Cleaning, Coating, and Potting

Except for the FM series, cleaning, coating and potting must not be carried out. Consult KEMET if this type of procedure is necessary. Terminals should be dried at less than the maximum operating temperature after cleaning. AEC-Q200 compliance FMD type is applicable to MIL-STD-202 option 4.

3. Storage

3.1 Temperature and humidity

Make sure that the supercapacitor is stored according to the following conditions: Temperature: 5 – 35°C (Standard 25°C), Humidity: 20 – 70% (Standard: 50%). Do not allow the build up of condensation through sudden temperature change.

3.2 Environment conditions

Make sure there are no corrosive gasses such as sulfur dioxide, as penetration of the lead terminals is possible. Always store this item in an area with low dust and dirt levels. Make sure that the packaging will not be deformed through heavy loading, movement and/or knocks. Keep out of direct sunlight and away from radiation, static electricity and magnetic fields.

3.3 Maximum storage period

This item may be stored up to one year from the date of delivery if stored at the conditions stated above.

Dismantling

There is a small amount of electrolyte stored within the capacitor. Do not attempt to dismantle as direct skin contact with the electrolyte will cause burning. This product should be treated as industrial waste and not be disposed of by fire.

KEMET Electronics Corporation Sales Offices

For a complete list of our global sales offices, please visit www.kemet.com/sales.

Disclaimer

All product specifications, statements, information and data (collectively, the "Information") in this datasheet are subject to change. The customer is responsible for checking and verifying the extent to which the Information contained in this publication is applicable to an order at the time the order is placed. All Information given herein is believed to be accurate and reliable, but it is presented without guarantee, warranty, or responsibility of any kind, expressed or implied.

Statements of suitability for certain applications are based on KEMET Electronics Corporation's ("KEMET") knowledge of typical operating conditions for such applications, but are not intended to constitute – and KEMET specifically disclaims – any warranty concerning suitability for a specific customer application or use. The Information is intended for use only by customers who have the requisite experience and capability to determine the correct products for their application. Any technical advice inferred from this Information or otherwise provided by KEMET with reference to the use of KEMET's products is given gratis, and KEMET assumes no obligation or liability for the advice given or results obtained.

Although KEMET designs and manufactures its products to the most stringent quality and safety standards, given the current state of the art, isolated component failures may still occur. Accordingly, customer applications which require a high degree of reliability or safety should employ suitable designs or other safeguards (such as installation of protective circuitry or redundancies) in order to ensure that the failure of an electrical component does not result in a risk of personal injury or property damage.

Although all product-related warnings, cautions and notes must be observed, the customer should not assume that all safety measures are indicated or that other measures may not be required.

When providing KEMET products and technologies contained herein to other countries, the customer must abide by the procedures and provisions stipulated in all applicable export laws and regulations, including without limitation the International Traffic in Arms Regulations (ITAR), the US Export Administration Regulations (EAR) and the Japan Foreign Exchange and Foreign Trade Act.

KEMET is a registered trademark of KEMET Electronics Corporation.